

### KEY FEATURES

- Clock deskew PLL with multiplication ability
- High VCO frequency of 800-1600MHz
- Supports a wide output frequency range of 15MHz – 1600 MHz.
- High input frequency range supported: 15MHz – 750 MHz
- Two pairs of supply : 2.5V +/- 10%, 1.2V +/-10%
- Low peak to peak period jitter of 2% of the output period
- Low peak to peak input to output jitter of 3% of the output period
- Excellent PSRR: can tolerate up to 50mV noise on the 2.5V supply and up to 30 mV noise on the 1.2V supply
- Compact foot print : Contact [ip@cosmiccircuits.com](mailto:ip@cosmiccircuits.com)
- Low-power : Contact [ip@cosmiccircuits.com](mailto:ip@cosmiccircuits.com)
- Chartered 65nm LPE process

### OVERVIEW

The CC1516DSPLL-C65LPE clock multiplying deskew PLL is capable of supporting an input reference clock as low as 15MHz to a VCO frequency as high as 1.6GHz.. The PLL has a good input to output jitter performance in the presence of power-supply noise which makes it suitable for clock skew removal applications

### DIFFERENTIATION

- Low input to output jitter with wide-range VCO and wide range of input reference clock.
- Compact foot-print and low-power consumption
- Good power supply noise rejection.

### APPLICATIONS

- Skew removal in clock tree networks.

### BLOCK DIAGRAM

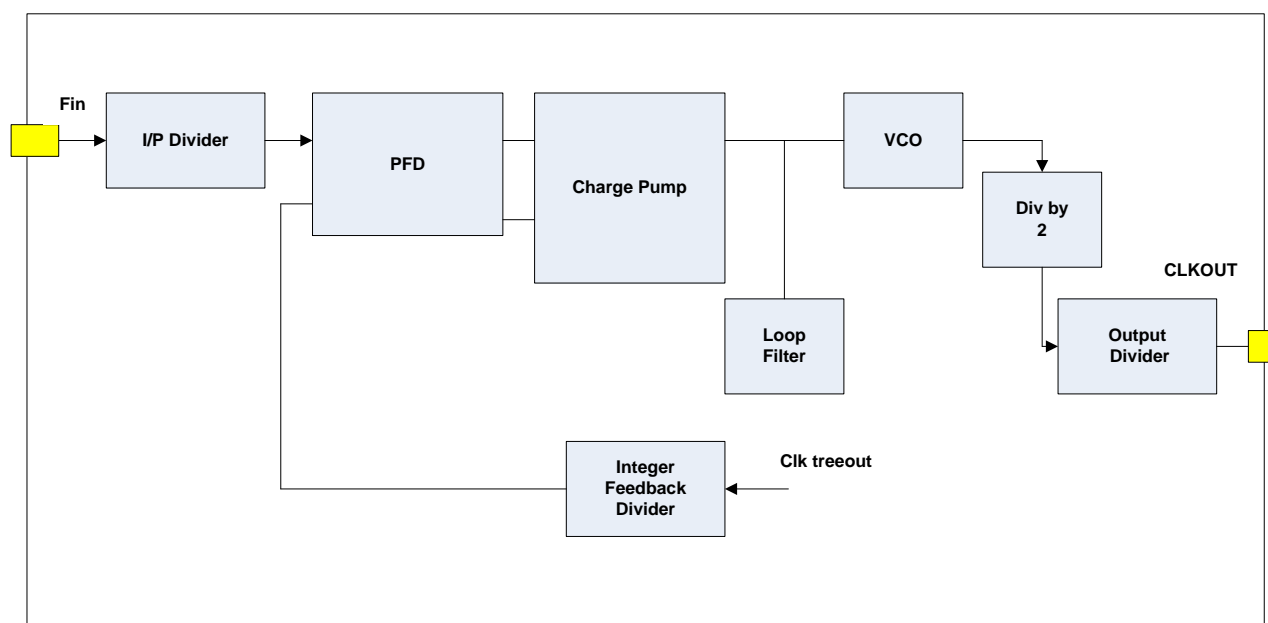

### SPECIFICATIONS TABLE

Parameter		Condition	Value			Units
			Min	Nom	Max	
Power Supply	VDDA		2.25	2.5	2.75	V
	VDDD		1.08	1.2	1.32	
Temperature			-40		125	C
Reference Frequency			15		750	MHz
Divided reference frequency			15		750	MHz
VCO Frequency			800		1600	MHz
Input divider				1		Counts
Feedback divider			1		4	Counts
Output Post-division			1		4	Counts
Output frequency			15		1600	MHz
Cock tree delay		Measured in % of reference %			20	%
Output clock duty cycle		For divide by 1 and even output division	48		52	%
		Odd output division	45		55	%
Frequency settling after power-up			350 divided reference cycles			
Jitter – pk-pk period jitter		Measured in % of Output period		2		%
Jitter- pk-pk input to output jitter		Measured in % of Output period		3		%
Tolerable Supply Noise - peak	VDDA	Square wave			50	mV
	VDDD				30	
Power			Contact <a href="mailto:ip@cosmiccircuits.com">ip@cosmiccircuits.com</a>			mW
Area			Contact <a href="mailto:ip@cosmiccircuits.com">ip@cosmiccircuits.com</a>			mm <sup>2</sup>
Process			Chartered 65 nm LPE process			
Status			Under Development			

**Note-1:** Product specifications are subject to change without notice. No responsibility is assumed for use of information herein.

**Note-2:** Products specifications such as that described above can typically be altered and customized for specific applications. Contact Cosmic Circuits for more information.

## ABOUT COSMIC CIRCUITS

Cosmic Circuits is a provider of differentiated and complex Analog, Mixed-Signal & RF Silicon IP cores. We create and provide IP cores that are best-in-class and thereby make our customers' solutions differentiated and low-cost.

Cosmic Circuits has quickly grown to be a company with the potential to become the destination of choice for world-wide customers for their complex and differentiated Analog, Mixed-Signal & RF Intellectual Property needs.

## DIFFERENTIATED IPS

We endeavor to create and provide Analog-IP solutions that are unique in functionality, burn the least amount of power, and take up minimal silicon die-area. 'Best-in-Class' is our Mantra. By using our analog-IP cores, our customers can expect their solution not to be disadvantaged because of analog, and even better, let the analog stand-out as a differentiating factor for the entire solution.

We value our unique blend of deep and broad analog skills and understanding of systems. Our customers can engage with our experts on the type of customization that needs to be done, or the kind of trade-offs to make, and expect the interaction to be a rewarding experience.

## DELIVERABLES

We provide the following deliverables to aid quick and reliable integration into the design flow. Please contact us for any additional views.

- ✓ GDSII
- ✓ Netlist (Spice format for LVS)
- ✓ Footprint (LEF format)
- ✓ User documentation
- ✓ Module integration guidelines
- ✓ Datasheet
- ✓ Silicon validation report (where available)
- ✓ Evaluation board (where available)

## LICENSING AND CUSTOMIZATION

Our engagements-models includes single-use and multi-use licensing of our IP-cores, Customization of IP-cores, Process porting of the cores to the customers' target process, turn-key development and licensing of customized IP cores and full-chip solutions, as well as supply of Known-Good-Dies (KGD) of full-chip ICs.

## SUPPORT

We consider ourselves successful when our customers succeed. We offer active support, both during the chip integration phase and during the product-ramp phase. We offer on-site support when needed. With Cosmic Circuits, our customers can be assured of a reliable partner interested in the success of the end product.

**Contact: Cosmic Circuits Pvt. Ltd.,**

303, A-Block, AECS Layout, Kundalahalli, Bangalore, India – 560037

**Phone:** +91-80-40526200 **Fax:** +91-80-41162255 **Email:** [ip@cosmiccircuits.com](mailto:ip@cosmiccircuits.com)

**Url:** <http://www.cosmiccircuits.com>