

KEY FEATURES

- Multiphase DLL with low jitter suitable for DDR applications
- Peak-to-peak period jitter of 2 % at the final clock out.
- Low static phase offset of ± 50 ps
- Supports a wide input frequency range of 150MHz-900MHz
- Programmable delay of 0 to 50% of the input clock period available with delay adjustment step size of 1% of the input period
- Single pair of Power Supply
 - $1.2V \pm 10\%$
- Core Cell Area: Contact ip@cosmiccircuits.com
- Low-power: Contact ip@cosmiccircuits.com
- Chartered 65nm LPE process

OVERVIEW

CC150900DLL-C65LPE is ideal for generating low jitter programmable delay suitable for DDR applications. The DLL supports an input range of 150MHz – 900 MHz and can generate a delay of 0 to 50% of the input clock period with programmable step size of with low period jitter of 2% p-p at the final clock output. This makes it suitable for DDR applications.

DIFFERENTIATION

- Single supply operation
- Low period jitter with wide range of input reference clock.
- Very high programmable delay range with very fine resolution
- Compact foot-print and low-power consumption
- Good power supply noise rejection

APPLICATIONS

- Delayed STROBE generation in DDR applications.

BLOCK DIAGRAM

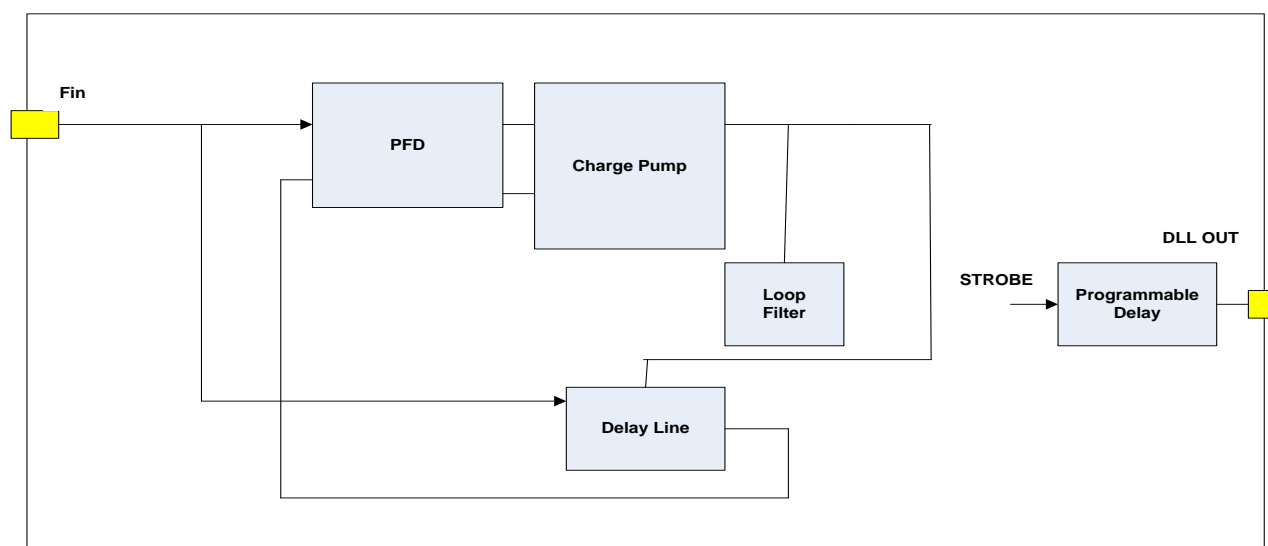

SPECIFICATIONS TABLE

| Parameter | Condition | Value | | | Units |
|---|--------------------------------|--|-----|------|-----------------|
| | | Min | Nom | Max | |
| Power supply | | 1.08 | 1.2 | 1.32 | V |
| Temperature | | -40 | | 125 | C |
| Input Frequency | | 150 | | 900 | MHz |
| Delay range | Measured in % of Input Period | 0 | | 50 | % |
| Delay adjustment step | Measured in % of Input Period | | | 1 | % |
| Static phase offset | | -50 | | 50 | Ps |
| Output clock duty cycle | | 48 | | 52 | % |
| Lock time | | 300 reference cycles | | | |
| p-p Jitter – cycle to cycle at the final clock output | Measured in % of Output Period | 2 | | | % |
| Tolerable Supply Noise | | 30 | | | mV |
| Power | | Contact ip@cosmiccircuits.com | | | mW |
| Area | | Contact ip@cosmiccircuits.com | | | mm ² |
| Process | | Chartered 65 LPE process | | | |
| Status | | Under Development | | | |

Note-1: Product specifications are subject to change without notice. No responsibility is assumed for use of information herein.

Note-2: Products specifications such as that described above can typically be altered and customized for specific applications. Contact Cosmic Circuits for more information.

ABOUT COSMIC CIRCUITS

Cosmic Circuits is a provider of differentiated and complex Analog, Mixed-Signal & RF Silicon IP cores. We create and provide IP cores that are best-in-class and thereby make our customers' solutions differentiated and low-cost.

Cosmic Circuits has quickly grown to be a company with the potential to become the destination of choice for world-wide customers for their complex and differentiated Analog, Mixed-Signal & RF Intellectual Property needs.

DIFFERENTIATED IPS

We endeavor to create and provide Analog-IP solutions that are unique in functionality, burn the least amount of power, and take up minimal silicon die-area. 'Best-in-Class' is our Mantra. By using our analog-IP cores, our customers can expect their solution not to be disadvantaged because of analog, and even better, let the analog stand-out as a differentiating factor for the entire solution.

We value our unique blend of deep and broad analog skills and understanding of systems. Our customers can engage with our experts on the type of customization that needs to be done, or the kind of trade-offs to make, and expect the interaction to be a rewarding experience.

DELIVERABLES

We provide the following deliverables to aid quick and reliable integration into the design flow. Please contact us for any additional views.

- ✓ GDSII
- ✓ Netlist (Spice format for LVS)
- ✓ Footprint (LEF format)
- ✓ User documentation
- ✓ Module integration guidelines
- ✓ Datasheet
- ✓ Silicon validation report (where available)
- ✓ Evaluation board (where available)

LICENSING AND CUSTOMIZATION

Our engagements-models includes single-use and multi-use licensing of our IP-cores, Customization of IP-cores, Process porting of the cores to the customers' target process, turn-key development and licensing of customized IP cores and full-chip solutions, as well as supply of Known-Good-Dies (KGD) of full-chip ICs.

SUPPORT

We consider ourselves successful when our customers succeed. We offer active support, both during the chip integration phase and during the product-ramp phase. We offer on-site support when needed. With Cosmic Circuits, our customers can be assured of a reliable partner interested in the success of the end product.

Contact: Cosmic Circuits Pvt. Ltd.,

303, A-Block, AECS Layout, Kundalahalli, Bangalore, India – 560037

Phone: +91-80-40526200 **Fax:** +91-80-41162255 **Email:** ip@cosmiccircuits.com

Url: <http://www.cosmiccircuits.com>