

### KEY FEATURES

- Integer PLL with low accumulated jitter, suitable for analog sampling applications
- Long-term jitter (accumulated rms): 15pS
- Supports a wide-range of input frequencies suitable for mobile and fixed applications for WLAN and WiMax: 13MHz, 19.2MHz, 20MHz, 26MHz, 38.4MHz, 40MHz input
- High VCO frequency of 1500-2200Mhz provides flexibility in input and output frequency combinations
- Power Supply
  - 2.5V $\pm$  10%
  - 1.2V $\pm$  5%
- Core Cell Area: [Contact ip@cosmiccircuits.com](mailto:ip@cosmiccircuits.com)
- Low-power: [Contact ip@cosmiccircuits.com](mailto:ip@cosmiccircuits.com)
- UMC 90nm 1P6M LL process, with 2.5V IO MOS

### OVERVIEW

CC1322INPLL-U90LL is ideal for generating the analog sampling frequencies at a low accumulated rms jitter of 15pS. Its low period-jitter makes it suitable for systems implementing high-speed data-transfers. Its high VCO frequency of 2.2GHz makes it versatile in supporting a variety of input frequencies including 13MHz, 19.2MHz, 20MHz, 26MHz, 38.4MHz, 40MHz. This makes it suitable both for mobile and fixed environments in communication applications such as WLAN and WiMax.

### DIFFERENTIATION

This PLL can be used to generate clocks for multiple standards and supporting multiple input and output frequencies. This is made possible by the high VCO frequency and other internal design techniques. The high PSRR and the low-power are other useful aspects.

### APPLICATIONS

- Clock for analog sampling
- WLAN, WiMax, communication systems

### BLOCK DIAGRAM

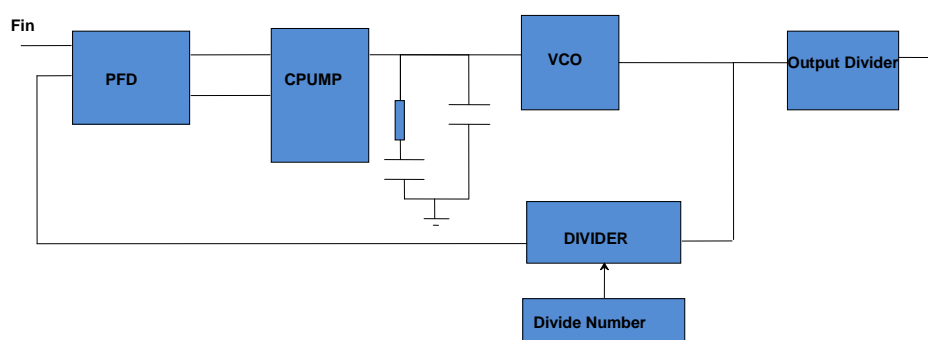

### SPECIFICATIONS TABLE

Parameter		Condition	Value			Units
			Min	Nom	Max	
Power Supply	VDD33		2.25	2.5	2.75	V
	VDD12		1.14	1.2	1.26	V
Temperature			-40		125	C
Input Frequency			12	13,19,2, 20,26, 38.4,40		MHz
VCO Frequency			1500		2200	MHz
Feedback divider (programmable)			32		254	Counts
Output post-divider			24, 26			Counts
Output frequency			Divided from VCO max of 2.2GHz per output divider			MHz
Output clock duty cycle			50			%
Frequency settling after power-up		13MHz input			60	μS
Jitter – accumulated long-term RMS					15	pS
Tolerable Supply Noise						
VDD33					50	mV
VDD12					20	mV
Power			Contact <a href="mailto:ip@cosmiccircuits.com">ip@cosmiccircuits.com</a>			mW
Area			Contact <a href="mailto:ip@cosmiccircuits.com">ip@cosmiccircuits.com</a>			mm <sup>2</sup>
Process			UMC 90nm LP			
Status			Silicon Proven			

**Note-1:** Product specifications are subject to change without notice. No responsibility is assumed for use of information herein.

**Note-2:** Products specifications such as that described above can typically be altered and customized for specific applications. Contact Cosmic Circuits for more information.

## ABOUT COSMIC CIRCUITS

Cosmic Circuits is a provider of differentiated and complex Analog, Mixed-Signal & RF Silicon IP cores. We create and provide IP cores that are best-in-class and thereby make our customers' solutions differentiated and low-cost.

Cosmic Circuits has quickly grown to be a company with the potential to become the destination of choice for world-wide customers for their complex and differentiated Analog, Mixed-Signal & RF Intellectual Property needs.

## DIFFERENTIATED IPS

We endeavor to create and provide Analog-IP solutions that are unique in functionality, burn the least amount of power, and take up minimal silicon die-area. 'Best-in-Class' is our Mantra. By using our analog-IP cores, our customers can expect their solution not to be disadvantaged because of analog, and even better, let the analog stand-out as a differentiating factor for the entire solution.

We value our unique blend of deep and broad analog skills and understanding of systems. Our customers can engage with our experts on the type of customization that needs to be done, or the kind of trade-offs to make, and expect the interaction to be a rewarding experience.

## DELIVERABLES

We provide the following deliverables to aid quick and reliable integration into the design flow. Please contact us for any additional views.

- ✓ GDSII
- ✓ Netlist (Spice format for LVS)
- ✓ Footprint (LEF format)
- ✓ User documentation
- ✓ Module integration guidelines
- ✓ Datasheet
- ✓ Silicon validation report (where available)
- ✓ Evaluation board (where available)

## LICENSING AND CUSTOMIZATION

Our engagements-models includes single-use and multi-use licensing of our IP-cores, Customization of IP-cores, Process porting of the cores to the customers' target process, turn-key development and licensing of customized IP cores and full-chip solutions, as well as supply of Known-Good-Dies (KGD) of full-chip ICs.

## SUPPORT

We consider ourselves successful when our customers succeed. We offer active support, both during the chip integration phase and during the product-ramp phase. We offer on-site support when needed. With Cosmic Circuits, our customers can be assured of a reliable partner interested in the success of the end product.

**Contact: Cosmic Circuits Pvt. Ltd.,**

303, A-Block, AECS Layout, Kundalahalli, Bangalore, India – 560037

**Phone:** +91-80-40526200 **Fax:** +91-80-41162255 **Email:** [ip@cosmiccircuits.com](mailto:ip@cosmiccircuits.com)

**Url:** <http://www.cosmiccircuits.com>