

KEY FEATURES

- Integer PLL with low accumulated jitter, suitable for analog sampling applications
- Long-term jitter (accumulated rms): 15pS
- High VCO frequency of around 2GHz provides flexibility in input and output frequency combinations
- Outputs:
 - 80MHz and 160MHz output for ADC and DAC sampling respectively.
 - 44MHz average frequency output for clocking digital circuits
 - Can be customized to other output frequencies
- Power Supply
 - 2.25V-3.6V
 - 1.1V \pm 5%
- Compact Foot-print
- Low-power
- TSMC 40nm 1P6M LP process, with 2.5V IO MOS

OVERVIEW

CC1322INPLL-T40LP is ideal for generating the analog sampling frequencies at a low accumulated rms jitter of 15pS. Its low period-jitter makes it suitable for systems implementing high-speed data-transfers. Its high VCO frequency of 2GHz makes it versatile in supporting a variety of input frequencies to produce a given output frequency. The input-divider, feedback-divider and output divider are all independently programmable, providing flexibility.

DIFFERENTIATION

This PLL can be used to generate clocks for multiple standards and supporting multiple input and output frequencies. This is made possible by the high VCO frequency. The jitter is low, making it useful for analog sampling applications and high-speed interfaces. The high PSRR and the low-power are other useful aspects.

APPLICATIONS

- Clock for analog sampling
- Serdes, DD3, interfaces
- WLAN, WiMax, communication systems

BLOCK DIAGRAM

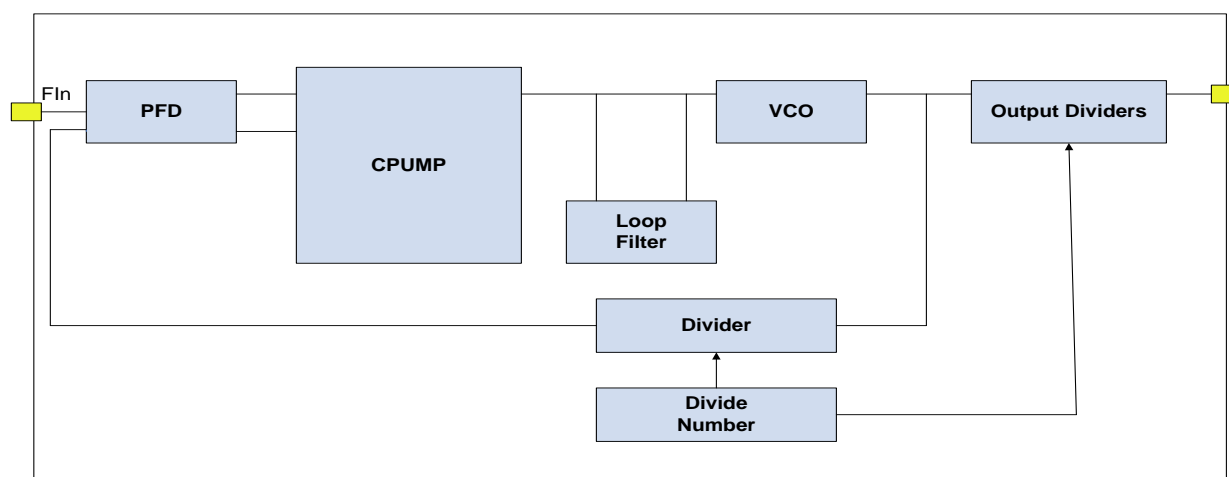

SPECIFICATIONS TABLE

Parameter		Condition	Value			Units
			Min	Nom	Max	
Power Supply	VDD33		2.25	2.5	3.6	V
	VDD12		1.05	1.1	1.16	V
Temperature			-40		125	C
Input Frequency (F_{REF})			13,19.2,20,26,38.4,40			MHz
Input Divider			1		32	Counts
VCO Frequency		$F_{REF} = 13M,26M$		1920		MHz
		$F_{REF} = 19.2M,20M,38.4M,40M$		2080		MHz
Feedback divider (programmable)		Only even division numbers	2		128	Counts
Output divider (programmable)			2		1024	Counts
Output clock duty cycle			40		60	%
Frequency settling after power-up		With band gap active and output frequency settling of 1% final frequency		60		μ S
Jitter – accumulated long-term RMS				15		pS
Period jitter		The spec is @ VCO output. The period jitter of an output clock will be measured and back calculated for VCO frequency	-50s		50	pS
Power			Contact ip@cosmiccircuits.com			mW
Area			Contact ip@cosmiccircuits.com			mm ²
Process			TSMC 40nm LP Process			
Status			Silicon proven			

Note-1: Product specifications are subject to change without notice. No responsibility is assumed for use of information herein.

Note-2: Products specifications such as that described above can typically be altered and customized for specific applications. Contact Cosmic Circuits for more information.

ABOUT COSMIC CIRCUITS

Cosmic Circuits is a provider of differentiated and complex Analog, Mixed-Signal & RF Silicon IP cores. We create and provide IP cores that are best-in-class and thereby make our customers' solutions differentiated and low-cost.

Cosmic Circuits has quickly grown to be a company with the potential to become the destination of choice for world-wide customers for their complex and differentiated Analog, Mixed-Signal & RF Intellectual Property needs.

DIFFERENTIATED IPS

We endeavor to create and provide Analog-IP solutions that are unique in functionality, burn the least amount of power, and take up minimal silicon die-area. 'Best-in-Class' is our Mantra. By using our analog-IP cores, our customers can expect their solution not to be disadvantaged because of analog, and even better, let the analog stand-out as a differentiating factor for the entire solution.

We value our unique blend of deep and broad analog skills and understanding of systems. Our customers can engage with our experts on the type of customization that needs to be done, or the kind of trade-offs to make, and expect the interaction to be a rewarding experience.

DELIVERABLES

We provide the following deliverables to aid quick and reliable integration into the design flow. Please contact us for any additional views.

- ✓ GDSII
- ✓ Netlist (Spice format for LVS)
- ✓ Footprint (LEF format)
- ✓ User documentation
- ✓ Module integration guidelines
- ✓ Datasheet
- ✓ Silicon validation report (where available)
- ✓ Evaluation board (where available)

LICENSING AND CUSTOMIZATION

Our engagements-models includes single-use and multi-use licensing of our IP-cores, Customization of IP-cores, Process porting of the cores to the customers' target process, turn-key development and licensing of customized IP cores and full-chip solutions, as well as supply of Known-Good-Dies (KGD) of full-chip ICs.

SUPPORT

We consider ourselves successful when our customers succeed. We offer active support, both during the chip integration phase and during the product-ramp phase. We offer on-site support when needed. With Cosmic Circuits, our customers can be assured of a reliable partner interested in the success of the end product.

Contact: Cosmic Circuits Pvt. Ltd.,

303, A-Block, AECS Layout, Kundalahalli, Bangalore, India – 560037

Phone: +91-80-40526200 **Fax:** +91-80-41162255 **Email:** ip@cosmiccircuits.com

Url: <http://www.cosmiccircuits.com>