

### KEY FEATURES

- Fractional-N PLL – 0.03PPM accuracy
- 10–40MHz input
- Max VCO frequency of 1500MHz
- Programmable output divider
- Low jitter:
  - 25pS rms long term
  - 5pS rms period jitter
- Core Cell Area: Contact [ip@cosmiccircuits.com](mailto:ip@cosmiccircuits.com)
- Samsung 90nm 1P7M CMOS, 1.8V IO MOS

### OVERVIEW

CC1015FNPLL-S90LP is a Fractional-N PLL that generates 480MHz output from a reference frequency in the range 10–40MHz. It uses a 27-bit sigma-delta modulator giving a precision of 0.03PPM. The PLL has good jitter performance of 25pS rms jitter. The programmable output divider can be used to generate output frequency from 100MHz to 250MHz. The PLL operates in the integer mode as well.

### DIFFERENTIATION

The PLL offers very low jitter, suitable for communication applications. The fractional-N capability provides a frequency resolution of 27-bits, and enables almost any frequency in and any frequency out within the specified range. This allows the use of a variety of CDMA/GSM compatible input clock frequencies and generates any desired output frequency for the system.

### APPLICATIONS

- Mobile Communication (WLAN, WiMax)
- Terrestrial Communication

### BLOCK DIAGRAM

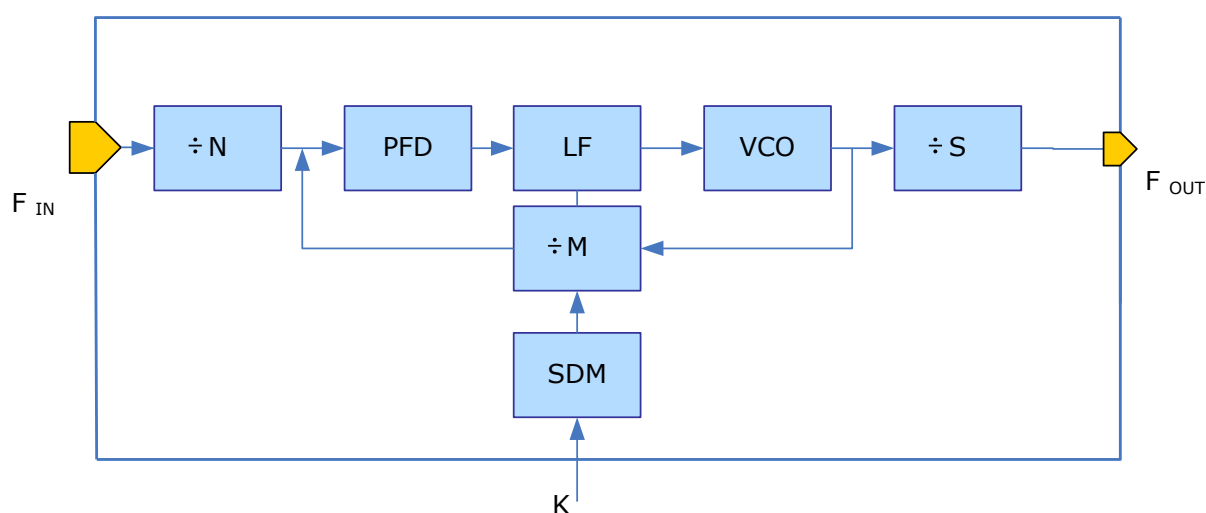

### SPECIFICATIONS TABLE

Parameter		Condition	Value			Units
			Min	Nom	Max	
Input Frequency			10		40	MHz
VCO Frequency			900		1500	MHz
Output divider range			6		12	
Output frequency step resolution		$F_{in} = 10\text{MHz}$		1		Hz
Power Supply	Analog		1.65	1.8	1.9	V
	Digital		1.1	1.2	1.3	V
Temperature			-40		125	C
Frequency settling time after Power up					1000	$\mu\text{S}$
Phase settling time after Power up					3000	$\mu\text{S}$
Output clock duty cycle		output-divider = 8	49		51	%
Period Jitter rms				5		pS
Accumulated jitter rms					25	pS
1.8V VDD					30	mV
1.2V VDD					10	mV
Process			Samsung 90nm Logic 7ML 1.8V IOMOS			
Status			Silicon Proven			

**Note-1:** Product specifications are subject to change without notice. No responsibility is assumed for use of information herein.

**Note-2:** Products specifications such as that described above can typically be altered and customized for specific applications. Contact Cosmic Circuits for more information.

## ABOUT COSMIC CIRCUITS

Cosmic Circuits is a provider of differentiated and complex Analog, Mixed-Signal & RF Silicon IP cores. We create and provide IP cores that are best-in-class and thereby make our customers' solutions differentiated and low-cost.

Cosmic Circuits has quickly grown to be a company with the potential to become the destination of choice for world-wide customers for their complex and differentiated Analog, Mixed-Signal & RF Intellectual Property needs.

## DIFFERENTIATED IPS

We endeavor to create and provide Analog-IP solutions that are unique in functionality, burn the least amount of power, and take up minimal silicon die-area. 'Best-in-Class' is our Mantra. By using our analog-IP cores, our customers can expect their solution not to be disadvantaged because of analog, and even better, let the analog stand-out as a differentiating factor for the entire solution.

We value our unique blend of deep and broad analog skills and understanding of systems. Our customers can engage with our experts on the type of customization that needs to be done, or the kind of trade-offs to make, and expect the interaction to be a rewarding experience.

## DELIVERABLES

We provide the following deliverables to aid quick and reliable integration into the design flow. Please contact us for any additional views.

- ✓ GDSII
- ✓ Netlist (Spice format for LVS)
- ✓ Footprint (LEF format)
- ✓ User documentation
- ✓ Module integration guidelines
- ✓ Datasheet
- ✓ Silicon validation report (where available)
- ✓ Evaluation board (where available)

## LICENSING AND CUSTOMIZATION

Our engagements-models includes single-use and multi-use licensing of our IP-cores, Customization of IP-cores, Process porting of the cores to the customers' target process, turn-key development and licensing of customized IP cores and full-chip solutions, as well as supply of Known-Good-Dies (KGD) of full-chip ICs.

## SUPPORT

We consider ourselves successful when our customers succeed. We offer active support, both during the chip integration phase and during the product-ramp phase. We offer on-site support when needed. With Cosmic Circuits, our customers can be assured of a reliable partner interested in the success of the end product.

**Contact: Cosmic Circuits Pvt. Ltd.,**

303, A-Block, AECS Layout, Kundalahalli, Bangalore, India – 560037

**Phone:** +91-80-40526200 **Fax:** +91-80-41162255 **Email:** [ip@cosmiccircuits.com](mailto:ip@cosmiccircuits.com)

**Url:** <http://www.cosmiccircuits.com>