

KEY FEATURES

- Clock multiplying PLL with spread spectrum generation ability at the output
- High VCO frequency of 800-1600MHz
- Supports a wide output frequency range of 60MHz – 1600 MHz.
- High input frequency range supported: 600 KHz – 750 MHz
- Programmable modulation depth selection of 0 - +/-1.5 %
- 15 KHz – 4MHz modulation frequency range supported
- Low peak to peak period jitter of 2% of the output period
- Single pair of supply required: 1.2V +/- 10 %
- Excellent PSRR: can tolerate up to 30mV noise on the 1.2V supply
- Compact foot print : Contact ip@cosmiccircuits.com
- Low-power : Contact ip@cosmiccircuits.com
- Chartered 65nm LPE process,

OVERVIEW

The CC0P616SSPLL-C65LPE clock multiplying PLL supports an input frequency as low as 600 KHz and a output frequency as high as 1600 MHz with ability to generate a spread spectrum clock depending on a input modulation profile.

A range of 800MHz to 1600 MHz in the VCO frequency and programmable dividers makes it versatile. The PLL has a good jitter performance in the presence of power-supply noise. It provides output clocks with low period jitter of 2 % of the output period. The spread spectrum modulation depth can be programmed between 0 - +/-1.5 % and the spreading rate can be programmed between 15 KHz – 4 MHz.

DIFFERENTIATION

- Single supply operation
- Spread spectrum ability with programmable rate and modulation depth.
- Low period jitter with wide-range VCO and wide range of input reference clock.
- Compact foot-print and low-power consumption
- Good power supply noise rejection.

APPLICATIONS

- Clocks with low EMI for digital applications.

BLOCK DIAGRAM

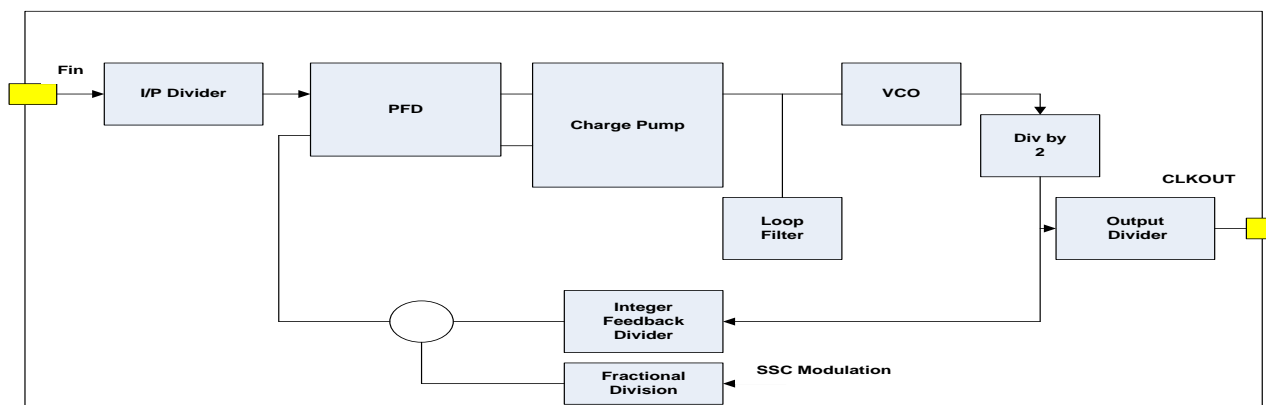

SPECIFICATIONS TABLE

Parameter	Condition	Value			Units
		Min	Nom	Max	
Power Supply		1.08	1.2	1.32	V
Temperature		-40		125	C
Reference Frequency		0.6		750	MHz
Divided reference frequency		0.6		100	MHz
VCO Frequency		800		1600	MHz
Input divider		1		64	Counts
Integer feedback divider		32		256	Counts
Fractional division				8	bits
Output Post-division		1		32	Counts
Output frequency		30		1600	MHz
Spread spectrum modulation depth		-1.5		+1.5	%
Spread spectrum modulation rate		15		4000	MHz
Output clock duty cycle	For divide by 1 and even output division	48		52	%
	Odd output division	45		55	%
Frequency settling after power-up		500 divided reference cycles			
Jitter – pk-pk period jitter	Measured in % of Output period	2			%
Tolerable Supply Noise - peak	Square wave	30			mV
Power		Contact ip@cosmiccircuits.com			mW
Area		Contact ip@cosmiccircuits.com			mm ²
Process		Chartered 65 nm LPE process			
Status		Under Development			

Note-1: Product specifications are subject to change without notice. No responsibility is assumed for use of information herein.

Note-2: Products specifications such as that described above can typically be altered and customized for specific applications. Contact Cosmic Circuits for more information.

ABOUT COSMIC CIRCUITS

Cosmic Circuits is a provider of differentiated and complex Analog, Mixed-Signal & RF Silicon IP cores. We create and provide IP cores that are best-in-class and thereby make our customers' solutions differentiated and low-cost.

Cosmic Circuits has quickly grown to be a company with the potential to become the destination of choice for world-wide customers for their complex and differentiated Analog, Mixed-Signal & RF Intellectual Property needs.

DIFFERENTIATED IPS

We endeavor to create and provide Analog-IP solutions that are unique in functionality, burn the least amount of power, and take up minimal silicon die-area. 'Best-in-Class' is our Mantra. By using our analog-IP cores, our customers can expect their solution not to be disadvantaged because of analog, and even better, let the analog stand-out as a differentiating factor for the entire solution.

We value our unique blend of deep and broad analog skills and understanding of systems. Our customers can engage with our experts on the type of customization that needs to be done, or the kind of trade-offs to make, and expect the interaction to be a rewarding experience.

DELIVERABLES

We provide the following deliverables to aid quick and reliable integration into the design flow. Please contact us for any additional views.

- ✓ GDSII
- ✓ Netlist (Spice format for LVS)
- ✓ Footprint (LEF format)
- ✓ User documentation
- ✓ Module integration guidelines
- ✓ Datasheet
- ✓ Silicon validation report (where available)
- ✓ Evaluation board (where available)

LICENSING AND CUSTOMIZATION

Our engagements-models includes single-use and multi-use licensing of our IP-cores, Customization of IP-cores, Process porting of the cores to the customers' target process, turn-key development and licensing of customized IP cores and full-chip solutions, as well as supply of Known-Good-Dies (KGD) of full-chip ICs.

SUPPORT

We consider ourselves successful when our customers succeed. We offer active support, both during the chip integration phase and during the product-ramp phase. We offer on-site support when needed. With Cosmic Circuits, our customers can be assured of a reliable partner interested in the success of the end product.

Contact: Cosmic Circuits Pvt. Ltd.,

303, A-Block, AECS Layout, Kundalahalli, Bangalore, India – 560037

Phone: +91-80-40526200 **Fax:** +91-80-41162255 **Email:** ip@cosmiccircuits.com

Url: <http://www.cosmiccircuits.com>